



MSVR



2011 Lotus Cup UK – Sporting & Technical Regulations

MSVR

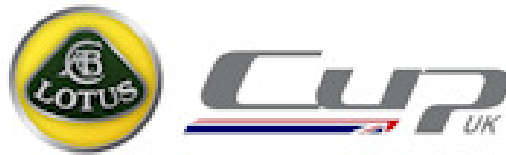

Published Copy

Signed _____

Date _____



2011 Lotus Cup UK – Sporting & Technical Regulations

Lotus Cup UK

Introduction

The Lotus Cup UK aims to provide a friendly, safe and financially viable Championship for those wishing to race a Lotus Elise, Exige, 211, 340R, Europa or Evora.

There are five groups within the Lotus Cup UK championship;

Production – With factory specification engines and limited modifications permitted.

2-Eleven – Specifically aimed at the Toyota supercharged Lotus 2-Eleven circuit car.

Exige Cup – Aimed at all Exige S2 variants – including the 2009 Lotus Exige Cup 260, Exige Cup 255, Exige Cup 240, Exige Cup 190 and Exige S.

Lotus Open – For Lotus cars that do not fall into the above categories – including Elise S2 supercharged Toyota, Modified K series Elise S1, S2, 340R, Europa. Other Lotus cars may be accepted by invitation only.

Evora – For standard specification Evora race cars.

Race meetings will either involve 20 minutes qualifying and a 60 or 90 minute race or 20 minutes qualifying and two races, one of 20 minute and one of 30 minutes. Races will be a mixture of rolling starts and standing starts. At some rounds there will be free practice.



2011 Lotus Cup UK – Sporting & Technical Regulations

1. SPORTING REGULATIONS – GENERAL

1.1 Title & Jurisdiction:

The Lotus Cup UK Championship is organised by LoTRDC Ltd and administered & promoted by LoTRDC Ltd in accordance with the General Regulations of the Royal Automobile Club Motor Sports Association (incorporating the provisions of the International Sporting Code of the FIA) and these Championship Regulations.

MSA Championship Permit No. **CH2011/R131**.

Race Status: **National B**

MSA Championship Grade: **C**

1.2 Officials:

1.2.1 Championship Coordinator:

Paul Golding, PO Box 1217, Maidstone, ME14 9JR
Email: paul@lotrdc.com
Phone: 0033 950 277 787
Fax: 0033 359 350 142

1.2.2 Championship Technical Director

Jez Braker
Email: jez@lotrdc.com

1.2.3 Licenced Eligibility Scrutineer: Chris Mount

1.2.4 Championship Eligibility Advisers: Phillip Hurn & Richard Short

1.2.5 Championship Stewards:

Jez Braker, Mark Anderson, Andrew Blacklock, Richard Short, Phillip Hurn, David Skeggs.

Any three of the above may reach a decision. Should it not be possible to achieve a quorum from the above list due to lack of availability or any perception of a conflict of interest the championship organisers reserve the right to introduce a steward not on this list.

1.2.6 Press Officer: Kevin Ritson

1.2.7 Clerk of the Course: Nick Turner

1.3 Competitor Eligibility:

1.3.1 Entrants must be fully paid up members of LoTRDC and be in possession of a 2011 Entrants license.

1.3.2 Drivers and Entrant/Drivers must be fully paid up valid membership card holding members of LoTRDC.

1.3.3 Drivers and Entrant/Drivers must be members of MSVR, be Registered for the Championship and be in possession of valid Competition (Racing) **National B STATUS** (minimum) Licence Or, be in possession of a valid Licence (featuring an E.U. flag) and medical, issued by the ASN of a member country of the European Union OR be in possession of a valid licence issued by Motorsport Ireland.



2011 Lotus Cup UK – Sporting & Technical Regulations

- 1.3.4 For any European round competitors will need a National A or above (or equivalent) licence.
- 1.3.5 Entry into the Lotus Cup UK will be by invitation of the organisers following full consideration of any Registration Form sent by post, fax or email to LoTRDC.
- 1.3.6 All necessary documentation must be presented for checking at all rounds when signing-on.

1.4 Registration:

- 1.4.1 The “Non-refundable” registration fee for the 2011 Lotus Cup UK Championship is £250 including VAT per driver if received by 31st January 2011 and £350 including VAT thereafter. Drivers registered for the 2011 Lotus Cup Europe &/or 2011 Elise Trophy may register for Lotus Cup UK for an additional £50+VAT over & above registration fees already paid.
- 1.4.2 All competitors must register for the Lotus Cup UK Championship by returning the Registration Form with the Registration Fee to the organisers prior to the Final Closing date for the first round being entered. The organisers reserve the right to accept registrations after this date. Acceptance of registration and the terms thereof is at the discretion of the Championship Organisers.
- 1.4.3 Such registration will only be complete when written acceptance is issued by the organisers. Registration does not guarantee entry to all races and a separate Race Entry Form and fee must be submitted for any race the registered competitor wishes to participate. Grid slots including reserves will be allocated on a “First Come First Served” basis.
- 1.4.4 Registrations for the Lotus Cup UK Championship should be received 14 days prior to the event entered. The championship organisers reserve the right to allow a competitor to take part in the race if the registration is received after this date up until noon of the Thursday prior to the event. In this event the competitor may not score championship points at that event, but may win a trophy. The entry of the car, if accepted by the technical scrutineer, will count towards Group numbers. Competitors entering less than 14 days prior to the event may not appear in the official programme.
- 1.4.5 Registrations will be accepted from 1st November 2010 until the closing date for entries to the final round.
- 1.4.6 Permanent Competition numbers for the Lotus Cup UK will be appointed and supplied by the championship organisers. Number backgrounds and race numbers will be supplied by the organisers and must not be altered in any way. Competitors are responsible for ensuring the appropriate race numbers and backgrounds are attached to their vehicle. Competitors will be issued with one full set of championship decals by the championship organisers, but will be required to purchase replacements. Competitors may request championship numbers which may be allocated at the discretion of the organisers.

1.5 Rounds:

- 1.5.1 The 2011 Lotus Cup UK will consist of 9 rounds over 7 race meetings as follows:

Date:	Circuit:	No. Races
March 19/20	Snetterton 300	1 x 60 mins
April 16/17	Silverstone Arena GP	1 x 60 mins
June 25/26	Snetterton 300	1 x 60 mins
July 22-24	Brands Hatch GP	2 (1 x 20mins & 1 x 30 mins)
August 13/14	Donington Park	1 x 60 mins
Sept 30 & October 1/2	Spa Francorchamps	2 (1 x 20mins & 1 x 40 mins)
October 22	Brands Hatch Indy	1 x 60 mins



2011 Lotus Cup UK – Sporting & Technical Regulations

- 1.5.2 No refund of any part of the entry fee will be returned if due to Force Majeure the duration of any track time is shortened or deleted from that which is publicised. In the event of Force Majeure, the Championship Organisers reserve the right to reduce the total number of Championship rounds.

1.6 Scoring:

- 1.6.1 Points will be awarded to Competitors listed as classified finishers in the Final Results as follows:-

Should more than one group have less than 6 starters in any race those groups will be treated as one for the accrual of points for that race.

1st - 20, 2nd - 18, 3rd - 16, 4th - 15, 5th - 14, 6th - 13, 7th - 12, 8th - 11, 9th - 10, 10th - 9, 11th - 8, 12th - 7, 13th - 6, 14th - 5, 15th - 4, 16th - 3, 17th - 2, 18th - 1.

One bonus point for each starter in group, up to a maximum of 10 points, will be awarded to each finisher in group and added to the finishing position score.
For clarification, a “starter” is any car that complies with MSA Regulation Q 12.7.

The competitor setting the fastest lap in each championship Group in each race will score one (1) additional point.

A bonus of 10 points will be awarded to every competitor entering the overseas round and starting at least one of the two races at that round.

A bonus of 10 points will be awarded to every competitor who starts all 9 races.

Any penalties issued by the Clerk of the Course resulting in MSA penalty points will be doubled and then deducted from the competitor's total championship score.

- 1.6.2 The totals from all the points scoring races in the 2011 Lotus Cup UK Championship will determine total Championship points.
- 1.6.3 Ties shall be resolved using the formula in the 2011 MSA Yearbook W.1.3.4.
- 1.6.4 It is permitted for a team or a group of drivers sharing a car to accumulate the points for that vehicle over the season provided that they enter the championship as an entrant and not as a solo entrant/driver. In this case the team concerned must possess and show their fully paid up and current MSA Entrant's licence when the driver signs on for the event.
- 1.6.5 Should a driver change cars during the course of the season, points may be carried over to the new car provided that car runs in the same group. A new set of points may be built up for drivers changing into a different group.

In the event that the Organisers *require* a car or driver to move to a different Group, Championship points may be carried over at the discretion of the Championship Organiser.

Only in exceptional circumstances and at the sole discretion of the Championship Organiser if a competitor changes to a car in a different group, may points be moved between groups.

- 1.6.6 Competitors will not be entitled to score Championship Points if they only participate in the 2011 Lotus Cup UK Championship in the last round or the penultimate round (or both). These cars WILL count towards total Group number of starters as set out in 1.6.1. These competitors will be required to register for the Championship and will be subject to a pro-rata registration fee.

**2011 Lotus Cup UK – Sporting & Technical Regulations****1.7 Awards:**

1.7.1 All awards are to be provided by the organisers.

1.7.2 Per Round: Trophies will be presented to 1st, 2nd and 3rd in each Group. Where there are less than 5 cars starting in a group trophies will not be awarded for 3rd place.

1.8 Bonuses: None**1.9 Presentations:**

Trophies are to be provided for presentation at the end of each race or at an end of the meeting presentation ceremony. Podium presentations at the end of each race will be for the driver that wins each group in the race. All Competitors are requested to attend the championship awards presentations in the Championship race centre 30 minutes after the finish of each race.

1.10 Entertainment Tax Liability:

In accordance with current government legislation, the promoter is legally obliged to withhold tax at the basic rate on all payments to non-UK resident sportsmen/women.

That is, those persons who do not have a normal permanent residence in the UK. The UK does not include the Isle of Man, Channel Islands or Eire. This means that, as the organiser, the [*] is required to deduct tax at the current rate applicable from any such payments they may make to non-UK residents.

Under certain circumstances, it may be possible for competitors to enter into an agreement with the Inland Revenue to limit the tax withheld. Any application for such an arrangement must be made in writing and not later than 30 days before the payment is due.

For further information contact:- The Inland Revenue, Foreign Entertainers Unit, Centre for Non-Residents, St John's House, Merton Road, Merseyside L69 9BB. Tel: 0151 472 6488 F 0151 472 6483.

1.11 Title to all Trophies:

In the event of any Provisional Results or Championship Tables being revised after any provisional presentations and such revisions affect the distribution of any awards the Competitors concerned must return such awards to the organisers in good condition within 7 days.

2 SPORTING REGULATIONS -JUDICIAL PROCEDURES**2.1 Rounds:**

2.1.1 In accordance with Section C of the 2011 MSA Yearbook and these regulations.

2.1.2 In accordance with Section C of the 2011 MSA Yearbook and these regulations.

3 SPORTING REGULATIONS -SERIES RACE MEETINGS & RACE PROCEDURES**3.1 Entries:**

3.1.1 Competitors are responsible for submitting the correct and fully completed entry forms, along with the correct entry fees prior to the event closing date. An entry will only be confirmed once full payment and a fully completed entry form has been received.



2011 Lotus Cup UK – Sporting & Technical Regulations

- 3.1.2 Incorrect or incomplete entries (including driver to be nominated entries) are to be held in abeyance until they are complete and correct. The date of receipt for acceptance of entry purposes shall be the date on which the Secretary of the Meeting receives the missing or corrected information or fee.
- 3.1.3 THERE WILL BE NO REFUNDS OR CREDITS GIVEN TO A COMPETITOR WITHDRAWING AFTER THE CLOSING DATE – UNDER ANY CIRCUMSTANCES.
- 3.1.4 Changes made to an entry after the closing date or late entries must apply for approval of acceptance by the stewards of the meeting before signing on.
- 3.1.5 The Maximum entry fee for every round shall be as stipulated in the Supplementary Regulations plus any late entry surcharge imposed by the club.
- 3.1.6 In the event of any rounds being oversubscribed the Organising Clubs in liaison with the coordinator / organiser may at their discretion run Qualification Races.
- 3.1.7 Reserves are to be nominated on the final list of entries published with Final Instructions or Amendment Sheet Bulletins. A number of reserves equivalent to the number of starters plus 20% will practice and replace withdrawn or retired entries. Reserve Number order is irrespective of group/class. If Reserves are given Grid Places prior to issue of the first Grid Sheets for any round the times set in Practice shall determine their grid positions. If Reserves are given places after publication of the grid sheet and prior to cars being collected in the Official “Assembly Areas” they will be placed at the rear of the Grid and be started without any time delay. Otherwise, they will be held in the pit lane and be released to start the race after the last car to start the GREEN FLAG LAP or last car to take the start has passed the start line or pit lane exit, whichever is the later. Such approval to start MUST be obtained from the Clerk of the Course.

3.2 Briefings:

Organisers will notify competitors of the times and locations for all Driver Briefings in the Final Instructions. It is mandatory that all Competitors must attend all briefings.

3.3 Practice:

- 3.3.1 The minimum period of practice to be as specified in the MSA Regulations in respect of circuit lengths.
- 3.3.2 Should any practice session be disrupted the Clerk of the Course shall not be obliged to resume the session or re-run sessions to achieve the series criteria and the decision of the Clerk of the Course shall be final.

3.4 Qualification:

- 3.4.1 Each driver should complete a minimum of 3 laps practice in the car to be raced in order to qualify for selection and order of precedence as set out in the MSA Regulation Q 4.5. The Clerk of the Course and/or Stewards of the Meeting shall have the right to exclude any driver whose practice times or driving are considered to be unsatisfactory - as per MSA Regulation Q 4.5.
- 3.4.2 The Clerk of the Course shall have the right to allow a driver who has not taken part in official qualifying, but who has taken part in the official practice session, to compete in the championship race.
- 3.4.3 Starting grid – the starting grids will be in accordance with the circuit track licence.

The grid for all races will be established by the fastest lap time in qualifying.



2011 Lotus Cup UK – Sporting & Technical Regulations

3.5 Races:

The standard minimum scheduled distance shall be as set out in 1.5.1 of these regulations. Should any race distance be reduced at the discretion of the Clerk of the Course or Stewards of the Meeting it shall still count as a full points scoring round. No last-lap board will be shown to competitors by officials.

3.6 Starts:

- 3.6.1 All race start countdowns are to have a minimum elapsed period of 3 minutes from the time all cars are released to form up the grid to the start of the Green Flag lap(s) in the formation as specified on the Track License for the Circuit.
- 3.6.2 The minimum countdown procedures/audible warning sequence shall be:
- For Standing & Rolling Starts:
- 1 minute to start of Green Flag lap -Start Engines/Clear Grid. 30 Seconds -Visible and audible warnings for the start of Green Flag lap.
- 3.6.3 The use of tyre heating/heat retention devices, tyre treatments and compounds is prohibited.
- 3.6.4 Any cars removed from the grid after the 1-minute stage or driven into the pits on Green Flag shall be held in the Pit Lane. They may start the race after the last car to take the start from the grid has passed the start line or pit lane exit, whichever is the later.
- 3.6.5 Any drivers unable to start the Green Flag lap or Start are required to indicate their situation as per MSA Regulation Q12.13.2. Any drivers unable to maintain grid positions on the Green Flag to the extent that all other cars are ahead of them may complete the Green Flag Lap. They MUST remain at the rear of the last row of the grid but ahead of any cars to be started with a time delay.
- 3.6.6 Excessive weaving to warm-up tyres using more than 50% of the track width and falling back in order to accelerate and practice starts, is prohibited.
- 3.6.7 For Standing Starts - A 5 Second Board will be shown to indicate that the Grid is complete. The red lights will be switched on five seconds after the board is withdrawn. In the event that the starting lights fail the Starter will revert to using the National Flag.
- 3.6.8 For Rolling Starts - The Pace car will pull off at the end of the pace lap. The cars will continue on their own with the pole position leading at a minimum speed of 70 kph and a maximum of 90 kph. A judge of fact may monitor the speed of the car in pole position by radar. Any divergence between the prescribed speeds (70/90 kph) before the start is given may result in a stop and go penalty. During the formation lap the red light will be on. No car may overtake another one before the starting signal is given. In the event that the starting lights fail the Starter will revert to using the National Flag.
- 3.6.9 The organisers reserve the right to employ an alternative starting procedure.

3.7 Race Stops:

- 3.7.1 Should the need arise to stop any race, RED LIGHTS will be switched on at the Start Line and RED FLAGS will be displayed at the start line and at all Marshals Signalling Points around the circuit.

This is the signal for all drivers to cease circulating at racing speeds, to slow to a safe and reasonable pace and to return to the starting grid area, which will automatically become a Parc Fermé area.



2011 Lotus Cup UK – Sporting & Technical Regulations

Cars may not enter the pits unless directed to do so. Work on cars already in the pits must cease when a race is stopped.

3.7.2 Case A – Less than two laps completed by the race leader.

The Race will be 'No contest'. The race will restart from the original grid positions. Competitors unable to take the restart may be replaced by reserves who will start from the back of the grid in reserve order. Gaps on the grid should not be closed up. The length of the restarted race will be determined by the Clerk of the Course.)

3.7.3 Case B – More than two laps completed by the race leader but less than 75% of the race completed by the leader.

The Race will restart from a grid set out by the finishing order of part one, (as per Q 5.4.3). The result of the race will be the finishing order at the end of part 2. The length of the restarted race will be determined by the Clerk of the Course.

3.7.4 If the leader has completed more than 75% of the race distance or duration it shall not be restarted and the results will be declared in accordance with MSA Regulation Q 5.4.3, unless the Clerk of the Course, in consultation with the Stewards deem it appropriate to restart the race.

3.8 Re-Scrutiny:

3.8.1 All vehicles reported involved in contact incidents during races or practice must be represented to the Scrutineers before continuing in the races or practice.

3.9 Pits and pit lane safety:

3.9.1 Pits: Entrants must ensure that the MSA, Circuit Management and Organising Club Safety Regulations are complied with at all times.

3.9.2 Pit Lane: The outer lane or lanes are to be kept unobstructed to allow safe passage of cars at all times. The onus shall be on all Drivers to take due care and observe a 60kph speed limit in the pit lane.

3.9.3 Refuelling: No refuelling at any time during the running of practice/qualifying. During races refuelling may only be carried out in accordance with the MSA Q13 Regulations, Circuit Management Regulations and the SRs or Final Instructions issued for each Circuit/Meeting.

3.10 Race Finishes:

After taking the Chequered Flag drivers are required to: Progressively and safely slow down, remain behind any competitors ahead of them, return to the Pit Lane Entrance/Paddock Entrance as instructed, comply with any directions given by Marshals or Officials and to keep the helmets on and harnesses done up while on the circuit or in the pit lane.

3.11 Results:

All Practice Timesheets, Grids, Race Results are deemed provisional until all vehicles are released by Scrutineers after Post Practice/Race Scrutineering and/or after completion of any Judicial or Technical Procedures.

3.12 Timing Modules:

3.12.1 All competitors will be required to fit Electronic Self Identification Modules to their cars for the purposes of accurate timing. Holders for these and detailed fitting instructions will be issued



2011 Lotus Cup UK – Sporting & Technical Regulations

with the transponders and it will be the responsibility of the competitor to fit these in the car in the position and manner specified. The Modules must be in place and functioning correctly for all series qualifying practice sessions and races. The setting and servicing of these items must only be carried out by properly authorised MSA licensed Timekeepers.

3.12.2 Any competitor who fails to fit a transponder to their car may not necessarily be timed by the official timekeepers for the event, at their discretion. In such a case, the competitor may start the race from the back of the grid but also may not necessarily feature on the results of the race, irrespective of their finishing position.

3.12.3 Competitors may not place electronic timing equipment within five metres of the official Start, Finish or any other official timing lines at any event or test session/day. Any such equipment placed within these zones will be removed.

3.13 Operation of Safety Car

The Safety Car will be brought into operation and run in accordance with Section Q, Appendix 2 of the MSA General Regulations. The Safety Car may be used in practice, qualifying and the race.

3.14 Pit Stops

3.14.3 Where a pit stop has been specified in the Supplementary Regs there will be a mandatory pit stop of 180 seconds. Each car must do one pit stop after the first 25 mins of each race and before the last 20 mins of each race. This time will be as per the MSA Official timekeepers who are Judges of Fact.

3.14.2 Pit Stops must only be carried out in accordance with the MSA 2011 Competitors Year Book Section Q13 Regulations, Circuit Management Regulations and the Supplementary Regulations or Final Instructions issued for each Circuit / Meeting.

3.14.3 Pit Lane Speed Limit will be 60KPH. The driver must adhere to pit lane speed limit and then bring the car to a stop only in the permitted pit area.

3.14.4 The timing of all pit stops will be done by timing beams or timing loops in the track at the entrance of the Pit Lane and the Pit Exit. The total time taken by a competing car between these two points in the pit lane will determine the length of the pit stops. These times are recorded by the appointed Licensed Timekeepers. Pit Lane speeds will be observed.

3.14.5 It is the sole responsibility of the team to police the stop/s. Any team shortening their pit-stop from the regulated time will receive a two lap penalty applied by the timekeepers at the end of the race.



2011 Lotus Cup UK – Sporting & Technical Regulations

4 CHAMPIONSHIP RACE PENALTIES:

4.1 Infringements of Technical Regulations:

4.1.1 Arising from post practice Scrutineering or Judicial Action:

Minimum Penalty: The provisions of MSA REGULATION C.3.3

4.1.2 Arising from post race Scrutineering or Judicial Action:

Minimum Penalty: The provisions of MSA Regulations: C.3.5.1 (a) & (b)

4.2 Infringements of non-technical MSA Regulations and the Sporting Regulations issued for the Championship:

As per 2011 MSA Judicial Procedure Regulations.

4.2.1 The Clerk of the Course has the option to impose Stop and Go or Drive Through penalties in accordance with Q 12.6.

4.2.2 The Clerk of the Course has the option to impose a penalty of up to 10 grid places at the next race/s of the Championship.



2011 Lotus Cup UK – Sporting & Technical Regulations

5 TECHNICAL REGULATIONS

5.1 Introduction:

The following Technical Regulations are set out in accordance with the MSA specified format.

It should be clearly understood that unless a modification or removal/change of an item is specifically permitted by these regulations, that any modification or removal/change or repositioning of an item is prohibited.

The provision of evidence to determine eligibility is the responsibility of the entrant/driver at all times.

5.2 General Description:

- 5.2.1 The Championship is open to all cars that comply with the five groups laid out below. All cars must be approved by the organisers.
- 5.2.2 Any vehicles affected by any changes made by the organisers will be notified at the earliest opportunity. The Championship Organiser reserves the right to adjust Group &/or car specification including power and weight specifications in the interest of equalizing competitiveness between models at any time during the championship.
- 5.2.3 Race Groups: Competitors will be appointed to a group upon registration (i.e. which Race Group they are entered).
- 5.2.4 Organisers may share grids with Lotus Cup Europe. Lotus Cup Europe drivers may register for the Lotus Cup UK Championship and compete for points. Where Lotus Cup UK and Lotus Cup Europe do share a grid identical Groups will be merged and the number of entrants in each Group will be the combined entry even if some drivers are not entered for the Championship. As an example for the avoidance of any doubt all cars meeting the 211 Group regulations be it Lotus Cup UK or Lotus Cup Europe competitors will be classed in one 211 Group. All cars will run to Lotus Cup UK championship regulations.
- 5.2.5 In considering whether to permit any car to race in the Championship the Organiser reserves the right to take into account, at any point during the season, its appearance and the standard of its presentation (including its interior) and may exclude any car the appearance of which they consider may prejudice the reputation of the Championship or is otherwise not acceptable.

5.3 Safety Requirements

- 5.3.1 For championship rounds in the United Kingdom, cars and drivers' equipment are subject to the provisions of MSA Regulations Section K - Safety Criteria - as an absolute minimum. It should be borne in mind that at all times the safety of the driver is paramount. All cars must comply with the following, K 1.6.1 – K 1.6.6 as applicable. Note 2011 MSA Regulations regarding permitted extinguishants. All competitors are advised to check their crash helmet, overalls, and seat belts have the correct standard number and sticker as per the 2011 MSA Yearbook.
- 5.3.2 Competitors should take special note that for rounds in mainland Europe, all personal safety equipment must conform to FIA standard, including – but not limited to – race suits, helmets, balaclavas, gloves, and boots
- 5.3.3 It is recommended that drivers of open top cars wear arm restraints whilst on track.

**2011 Lotus Cup UK – Sporting & Technical Regulations****5.4 GENERAL TECHNICAL REQUIREMENTS & EXCEPTIONS**

- 5.4.1 The Eligibility Scrutineer or their representative shall be the sole arbiters and shall be a judge of fact. Any finding as to whether or not any item or component is 'standard' or 'relevant' for the purpose of these regulations shall be a Judgement of Fact.
- 5.4.2 The decision of the Championship Organiser upon all matters in relation to interpretation, applications, breaches and enforcement of these regulations (including without limit, eligibility and Classification) shall be binding upon all competitors, who shall on registering for the Championship be deemed to have full knowledge of these regulations and to have accepted same in full.

5.5 GROUPS:

- 5.5.1 There will be five groups for Lotus Exige, Elise, 211, 340R, Europa or Evora. Groups are defined based on the type of car. The basic principal of this is as follows:

Group - Production – Standard and slightly modified cars

For Series 1 and 2 Elises with a maximum hub power of 151bhp (measured by TDI) and minimum combined weight of driver and car of 825kg. Also open to standard series 2 Exige and 111r Toyota NA engined cars with a maximum hub power of 172bhp (measured by TDI).

Group - 2-Eleven - Standard and slightly modified 2-Eleven cars

For 2-Eleven cars up to a maximum of 248bhp at the hubs (measure by TDI) with a minimum weight of 815KG including driver.

Group - Exige Cup – For Exige S2 Cup cars and S2 Exige variants

For S2 Exige cars up to a maximum of 260bhp at the hubs (measure by TDI) with a minimum weight of 910KG including driver.

Group - Lotus Open – For Elise S, Elise S1, Elise S2, Exige S1, 340R & Europa.

For all original engined Elise, Exige, 211, Europa and 340R variants not fitting into other groups. Other cars may be accepted on an invite, round by round basis. With a maximum power at the hubs of 240bhp (measured by TDI) and with a maximum power to weight of 285.7bhp/tonne including driver. No non-standard turbos are permitted.

Group – Evora

For all factory specification Evora race cars. With a maximum power at the hubs of 360bhp (measured by TDI) and with a maximum power to weight of 285.7bhp/tonne including driver. No non-standard turbos are permitted.

- 5.5.2 Vehicles do not have to reach the maximum power, the minimum weight, or the maximum power to weight figures defined within these regulations. They are MAXIMUM and MINIMUM values only.
- 5.5.3 Drivers must submit a technical document providing details of their car. This document will detail the specification of the vehicle for the entire season. Any changes that the competitor wishes to make to the specification of the vehicle throughout the season must be applied for in writing a minimum of 2 weeks before the next event for approval by the series Eligibility Scrutineer. They will then be required to submit their car to one or more power tests during the season to Torque Developments International PLC, Unit 5, The I.O. Centre, Motherwell Way, Thurrock, RM20 3LE (hereby referred to as TDI). The power test will provide the cars



2011 Lotus Cup UK – Sporting & Technical Regulations

power "at the hubs". Competitors are entirely responsible for any damage caused by the power testing. The organisers will use the figures obtained to police the maximum power and power to weight if relevant in each group.

- 5.5.4 Vehicles may have individual weights set dependent on their specification. Weight penalties may also be applied for exempted items which fall outside of individual class regulations.
- 5.5.5 Toyota engined cars should remain unmodified in standard factory specification for acceptance into the Production group. As a general rule the car should be as it left the showroom with only the addition of safety equipment.
- 5.5.6 Any new components released by Lotus Cars must be accepted for use in the series before competitors use them. The organisers will notify competitors by sending an official bulletin.

5.6 Group: Production

5.6.1 Series 1 and 2 Elise with Rover engine

5.6.1.1 Chassis: Production

5.6.1.1.1 The construction type, design and material must remain as standard. This includes the sub frame.

5.6.1.1.2 No additional bracing/supports may be added.

5.6.1.2 Bodywork: Production

5.6.1.2.1 All cars must retain the standard road car's profile, and be maintained to a high standard of finish, whilst it's understandable that damage may occur during a weekend, it's important that this is rectified before the next meeting. This is important to keep the image and profile of the series.

5.6.1.2.2 The organisers reserve the right to overrule any part that is felt to be outside the spirit of the series. If in any doubt about what is/is not acceptable, the onus is on the entrant to ask first.

5.6.1.2.3 All body panels must remain as standard production in size, shape, profile and material (i.e. Pre-preg GRP, Kevlar and Carbon fibre are not permitted).

5.6.1.2.4 Side scoops may be fitted, but must not protrude further than the side profile of the car. Only series 1 style side scoops are permitted on series 1 cars, and series 2 style on series 2 cars. Material is free.

5.6.1.2.5 Side scoop inner vents may be removed but the external holes in the clam must be standard size and profile. No clam material may be removed.

5.6.1.2.6 S1 Elise 'Sport 160' style rear wing may be fitted and material is free.

5.6.1.2.7 A small Front Spoiler/splitter that's within the profile of the car as shown in section 6.4 may be fitted and material is free.

5.6.1.2.8 Under trays must not exceed overall dimensions of the standard part. Ducts and holes within the tray may be relocated. Material is free.

5.6.1.2.9 Rear diffuser may be extended rearwards protruding no more than 50mm from the rear bodywork (measured from the rear clam where the diffuser is attached at the rear) and complying with the ground clearance rules in 5.6.5. Material is free.

**2011 Lotus Cup UK – Sporting & Technical Regulations**

- 5.6.1.2.10 The clam under rear grills (fog and reverse lights) may be removed however the grill must remain.
- 5.6.1.2.11 The body behind the number plate can be removed to an area no larger than a standard number plate (520mm x 130mm). If a hole is created it should be covered in mesh.
- 5.6.1.2.12 Wheel arch liners may be removed and the inner lip of the wheel arch reduced to allow tyre clearance.
- 5.6.1.2.13 Heater matrix, blower fan and ducting to distribution flap may be removed.
- 5.6.1.2.14 Interior must remain as standard with the exception of required items to meet MSA regulations. This exception to include safety seats and seat mounts which may be replaced with alternatives.
- 5.6.1.2.15 Steering wheel and steering wheel bosses may be replaced with a suitable alternative.
- 5.6.1.2.16 Glass must remain as E marked glass with the exception of the rear screen which may be replaced with a polycarbonate version.
- 5.6.1.2.17 Heated front screens are permitted and/or aftermarket electric fans may be installed to replace the standard heater.
- 5.6.1.2.18 An appropriate red warning light must be fitted to comply with MSA regulation K 5.1.
- 5.6.1.2.19 Supplementary gauges may be added such as oil temperature and pressure.
- 5.6.1.2.20 There should be substantial towing eyes securely fixed to the main structure of the vehicle, front and rear, within the confines of the body to enable the vehicle to be moved. Towing eyes should have a minimum internal diameter of 60mm. Towing eyes/towing points should be painted a contrasting bright color (Day-Glo red, orange or yellow). Q 19.1.3
- 5.6.1.2.21 Bonnet and boot lid fastenings and hinges may be modified or replaced.
- 5.6.1.2.22 The boot bulkhead may be modified to allow easier access to the engine (i.e. fitting an access panel), however it should remain a solid divide between boot and engine bay with only the standard factory designed holes. Cars converted from multi throttle bodied Elise derivatives (e.g. Sport 190) must have a boot divider and floor installed to replicate a standard boot.
- 5.6.1.2.23 Please check with the series eligibility scrutineer that the exact part you intend to fit is permitted if you are in any doubt over any of the above.
- 5.6.1.3 **Engine:** **Production**
- 5.6.1.3.1 Must not exceed a maximum power output of 151bhp at the hubs.
- 5.6.1.3.2 The power limit must be strictly adhered too – the organisers advise all drivers that their cars **MUST** be under this maximum as there will be no excuses should they be found to exceed them.
- 5.6.1.3.3 As per MSA regulations including J 5.4.1-3 (engines), J 5.10.1-2 (cooling), J 5.12.1 (oil systems), J 5.13.1-7 (fuel systems).
- 5.6.1.3.4 Engine must retain the standard inlet plenum (either plastic or VVC style alloy versions).

**2011 Lotus Cup UK – Sporting & Technical Regulations**

- 5.6.1.3.5 Engine must retain the standard single throttle body in un-modified form (MGF TF 52mm is permitted) – Multiple throttle bodies are not permitted.
- 5.6.1.3.6 Engines must retain a standard pattern exhaust manifold – (i.e. the standard Elise or Sport 160 “Janspeed big bore” version – not aftermarket 421 i.e. EBD etc).
- 5.6.1.3.7 Exhaust system after the manifold are free, although MSA regulations should of course be observed as 5.1.2.
- 5.6.1.3.8 Compression ratio must remain standard.
- 5.6.1.3.9 Engine rods, pistons and crankshaft may be balanced - however no materials may be added (e.g. no heavy metal crank inserts) or removed (beyond balancing) and the components themselves must be standard parts as fitted to either the VVC, sport 160 or standard Elise K engines. If, in renewing the bottom end, any parts are replaced by new items - they must be the exact specification/profile and material of the original parts in the appropriate derivative.
- 5.6.1.3.10 Heads are free but standard hydraulic tappets/followers must be retained and valve, valve guide, valve seat and valve spring dimensions limited to standard rover items as fitted to standard, VVC or VHPD heads.
- 5.6.1.3.11 Cams are free.
- 5.6.1.3.12 Heads may be ported and polished and intake manifold may be matched to the head.
- 5.6.1.3.13 Cams are free but standard hydraulic tappets/followers must be retained and valve and valve spring dimensions limited to standard rover items as fitted to standard, VVC or VHPD heads.
- 5.6.1.3.14 Vernier cam pulleys are permitted.
- 5.6.1.3.15 Air filters/induction is free up to the single throttle body.
- 5.6.1.3.16 Swept volume must remain standard (i.e. below 1800cc).
- 5.6.1.3.17 A Baffle may be fitted to the sump.
- 5.6.1.3.18 Addition of a water/oil or air/oil cooler is permitted.
- 5.6.1.3.19 Engine water cooling system is free (e.g. use of a remote thermostat, removal of cabin heater pipe work, up rated radiator, up rated cooling fans, up rated water pump)
- 5.6.1.3.20 Up rated engine, gearbox and clutch slave cylinder mounts are permitted.
- 5.6.1.3.21 Additional heat shielding may be added within the engine bay.
- 5.6.1.3.22 Alternator make is free but must be installed in standard position and working.
- 5.6.1.3.23 Crank accessory pulley is free.
- 5.6.1.3.24 Addition of a remote thermostat/PRT, water/oil or air/oil cooler is permitted on K series engined cars.
- 5.6.1.3.25 Lightweight flywheels are permitted, but must retain the standard clutch mounts and starter ring.



2011 Lotus Cup UK – Sporting & Technical Regulations

- 5.6.1.3.26 Clutch must remain standard pattern (AP or other upgraded clutch are permitted if same type as OEM).
- 5.6.1.3.27 Throttle cable to pedal linkage, gear selector cables and clutch cable may be replaced by up rated versions. Quick shift gear stick is also permitted.
- 5.6.1.4 **Suspensions:** **Production**
- 5.6.1.4.1 It is strongly recommended that all cars have upgraded rear toe link kits (A111D0127S or equivalent).
- 5.6.1.4.2 All wishbones/bushes/ball-joints/uprights/bearings must be as standard.
- 5.6.1.4.3 Uprights and steering arms may be modified to achieve more camber.
- 5.6.1.4.4 Dampers may be changed for single way adjustable (no remote canister types) and may have either bushed or spherical joints. All parts must be fitted directly to the original mounting points with no adaptor parts other than changes in mounting bush sizes.
- 5.6.1.4.5 Spring rates are free including use of helper springs.
- 5.6.1.4.6 Front anti roll bar may be replaced by an uprated one using the same design and mounts to original. No additional anti roll bars can be added (i.e. rears etc)
- 5.6.1.4.7 Must retain original steering rack. Quicker ratio pinion is allowed.
- 5.6.1.4.8 Steering arms may be changed from OEM but must retain standard ackerman and upright/wishbone mountings both physically and geometrically.
- 5.6.1.5 **Ride Height and Ground Clearance:** **Production**
- 5.6.1.5.1 See diagram 6.4 in appendices showing illustration of where ride height should be observed on the vehicle.
- 5.6.1.5.2 Ride height - no part of the car between all 4 wheel centers (excluding mud flaps) may be below 100mm.
- 5.6.1.5.3 Ground clearance - no part of the car (excluding mud flaps) should be below 80mm.
- 5.6.1.6 **Transmission:** **Production**
- 5.6.1.6.1 Ratios are free, but must be standard production item (after-market gear kits are not permitted).
- 5.6.1.6.2 LSD's are permitted.
- 5.6.1.7 **Electrics:** **Production**
- 5.6.1.7.1 As per MSA regulation J 5.14.1-7 (electrical systems).
- 5.6.1.7.2 Aftermarket and reprogrammed Engine Control Units (ECU) are permitted.
- 5.6.1.7.3 All ECU's must contain only one map.
- 5.6.1.7.4 If an aftermarket ECU is fitted drivers must make available to the Series Eligibility Scrutineer the hardware and software required to interrogate the vehicles ECU. If this is not made available the ECU may be sealed and the driver may not be permitted to race.



2011 Lotus Cup UK – Sporting & Technical Regulations

- 5.6.1.7.5 Battery size & type is free but must remain in the standard location and be capable of starting the car multiple times without external assistance.
- 5.6.1.7.6 Vehicle immobiliser and alarm system may be removed.
- 5.6.1.8 **Brakes:** **Production**
- 5.6.1.8.1 Discs are free (steel or iron only – bells are free)
- 5.6.1.8.2 Pads are free.
- 5.6.1.8.3 Calipers must remain standard (AP two pot fronts and Brembo sliding caliper rear).
- 5.6.1.8.4 Master cylinder must remain standard (single dual circuit item).
- 5.6.1.8.5 Brake flexible hoses are free (stainless steel braided recommended).
- 5.6.1.8.6 Fluid must be DOT 4 or 5.1.
- 5.6.1.8.7 Brake disk shields may be removed.
- 5.6.1.8.8 Ducting to the front brakes may be added but must not involve modification of bodywork.
- 5.6.1.9 **Wheels:** **Production**
- 5.6.1.9.1 Elise S1 max rim size front 7J15 min ET10 and rear 8J16 min ET10.
- 5.6.1.9.2 Elise S2 (K series) max rim size front 7J16 min ET18 and rear 8J17 min ET18.
- 5.6.1.9.3 All Wheels must be of metal construction with the exception of Magnesium which is not permitted. Multi-piece wheels are not permitted.
- 5.6.1.10 **Tyres:** **Production**
- 5.6.1.10.1 As supplied control tyre:
- Yokohama A048 LTS or Yokohama AO48R (M compound)
- | | |
|-----------|-----------|
| Series 1 | Series 2 |
| 195/50R15 | 195/50R16 |
| 225/45R16 | 225/45R17 |
- 5.6.1.10.2 No modifications to the tyres in any way, (any tyres suspected of being treated/modified will be excluded from the meeting).
- 5.6.1.10.3 It is not permitted to fill tyres with nitrogen
- 5.6.1.11 **Weights:** **Production**
- 5.6.1.11.1 Minimum weight of the vehicle including the driver is **825kg**.
- As an example;
- If a driver weighs 75kg the vehicle alone should weigh at least 750kg.
 - If a driver weighs 95kg the vehicle alone should weigh at least 730kg.
- 5.6.1.11.2 This weight is the minimum the car and driver combined must be in race trim after either a race or qualifying session as defined in J 5.15.1-5 (weight/ballast).

**2011 Lotus Cup UK – Sporting & Technical Regulations**

- 5.6.1.11.3 It is forbidden to use ballast to make up the weight (as in no lightening of the car then ballasting them back up).
- 5.6.1.11.4 Ballast may only be applied under direction from the organisers and where required shall be securely fixed in accordance with J 5.15.1-5.
- 5.6.1.11.5 Cars may have additional weight added to their minimum weights depending on vehicle specification. Current penalties are detailed in section 6.1.1.
- 5.6.1.12 **Fuel Tank/Fuel:** **Production**
- 5.6.1.12.1 As per MSA regulation J 5.13.1-13 where appropriate. Only pump fuel as defined by the 2011 MSA Year Book is permitted.
- 5.6.1.12.2 The standard fuel tank (in both dimensions and material) should be used unless replaced with a bag tank as described in MSA regulation K 4.1-3 (safety fuel cells).
- 5.6.1.12.3 Fuel lines are free.
- 5.6.1.12.4 All cars must have a minimum of 3L of fuel remaining in the tank at race finish.
- 5.6.1.12.5 Charcoal canister may be removed but a one way or rollover valve, venting to a safe area, must be fitted.
- 5.6.2 Series 2 Elise and Exige with Toyota Engines** **Production**
- 5.6.2.1 **Chassis:**
- 5.6.2.1.1 The construction type, design and material must remain as standard. This includes the sub frame.
- 5.6.2.1.2 No additional bracing/supports can be added with exception of a rear chassis brace kit (LOTAC05377).
- 5.6.2.2 **Bodywork:** **Production**
- 5.6.2.2.1 All cars must retain the standard road car's profile, and be maintained to a high standard of finish, whilst it's understandable that damage may occur during a weekend, it's important that this is rectified before the next meeting. This is important to keep the image and profile of the series.
- 5.6.2.2.2 The organisers reserve the right to overrule any part that is felt to be outside the spirit of the series. If in any doubt about what is/is not acceptable, the onus is on the entrant to ask first.
- 5.6.2.2.3 All body panels must remain as standard production in size, shape, profile and material (i.e. Pre-preg GRP, Kevlar and Carbon fibre are not permitted).
- 5.6.2.2.4 Exige and 111R S2 must remain as standard including, but not limited to, all body panels.
- 5.6.2.2.5 Interior must remain as standard with the exception of required items to meet MSA regulations. This exception to include safety seats and seat mounts which may be replaced with alternatives.
- 5.6.2.2.6 Steering wheel and steering wheel bosses may be replaced with a suitable alternative.



2011 Lotus Cup UK – Sporting & Technical Regulations

- 5.6.2.2.7 Glass must remain as E marked glass with the exception of the rear screen which may be replaced with a polycarbonate version.
- 5.6.2.2.8 An appropriate red warning light must be fitted to comply with MSA regulation K 5.1.
- 5.6.2.2.9 Supplementary gauges may be added such as oil temperature and pressure.
- 5.6.2.2.10 There should be substantial towing eyes securely fixed to the main structure of the vehicle, front and rear, within the confines of the body to enable the vehicle to be moved. Towing eyes should have a minimum internal diameter of 60mm. Towing eyes/towing points should be painted a contrasting bright color (Day-Glo red, orange or yellow). Q 19.1.3
- 5.6.2.2.11 Please check with the series eligibility scrutineer that the exact part you intend to fit is permitted if you are in any doubt over any of the above.

5.6.2.3 **Engine:** **Production**

- 5.6.2.3.1 Must not exceed a maximum power output of 172bhp at the hubs.
- 5.6.2.3.2 The power limit must be strictly adhered too – the organisers advise all drivers that their cars **MUST** be under this maximum as there will be no excuses should they be found to exceed them.
- 5.6.2.3.3 As per MSA regulations including J 5.4.1-3 (engines), J 5.10.1-2 (cooling), J 5.12.1 (oil systems), J 5.13.1-7 (fuel systems).
- 5.6.2.3.4 No engine modifications permitted including but not limited to airbox and exhaust system with the exception of the exhaust silencer which may be changed and a baffled sump which is permitted. The vehicle should remain as standard.
- 5.6.2.3.5 MSA regulations should be observed as 5.1.2.

5.6.3 **Suspensions:** **Production**

- 5.6.3.1.1 It is strongly recommended that all cars have upgraded rear toe link kits (A111D0127S or equivalent). It is recommended that cars are additionally fitted with rear chassis brace kit (LOTAC05377).
- 5.6.3.1.2 All wishbones/bushes/ball-joints/uprights/bearings must be as standard.
- 5.6.3.1.3 Uprights and steering arms may be modified to achieve more camber.
- 5.6.3.1.4 Dampers may be changed for single way adjustable (no remote canister types) and may have either bushed or spherical joints. All parts must be fitted directly to the original mounting points with no adaptor parts other than changes in mounting bush sizes.
- 5.6.3.1.5 Spring rates are free including use of helper springs.
- 5.6.3.1.6 Front anti roll bar may be replaced by an uprated one using the same design and mounts to original. No additional anti roll bars can be added (i.e. rears etc)
- 5.6.3.1.7 Must retain original steering rack. Quicker ratio pinion is allowed.
- 5.6.3.1.8 Steering arms may be changed from OEM but must retain standard ackerman and upright/wishbone mountings both physically and geometrically.
- 5.6.3.1.9

**2011 Lotus Cup UK – Sporting & Technical Regulations**

- 5.6.4 Ride Height and Ground Clearance:** **Production**
- 5.6.4.1.1 See diagram 6.4 in appendices showing illustration of where ride height should be observed on the vehicle.
- 5.6.4.1.2 Ride height - no part of the car between all 4 wheel centers (excluding mud flaps) may be below 100mm.
- 5.6.4.1.3 Ground clearance - no part of the car (excluding mud flaps) should be below 80mm.
- 5.6.5 Transmission:** **Production**
- 5.6.5.1.1 No transmission modifications permitted including but not limited to gearbox (including gear ratios).
- 5.6.5.1.2 LSDs are permitted.
- 5.6.6 Electrics:** **Production**
- 5.6.6.1.1 As per MSA regulation J 5.14.1-7 (electrical systems).
- 5.6.6.1.2 Aftermarket and reprogrammed Engine Control Units (ECU) are not permitted.
- 5.6.6.1.3 Lotus ECU reflash is permitted of T4 and T4E Lotus track upgrade.
- This relates to;
- T4 and T4e ECU - Track Upgraded
Part No. - ALS3M0215F, ALS3M0244F
Applications - S2 (Toyota) naturally aspirated cars
ECU with cam switch optimised for track use, moving switch point to high lift cam from 6200 rpm to 5750 rpm. All other functionality of the original ECU programme remain, preserving the full European emissions compliance of the vehicle.
- 5.6.6.1.4 Battery size & type is free but must remain in the standard location and be capable of starting the car multiple times without external assistance.
- 5.6.6.2 Brakes:** **Production**
- 5.6.6.2.1 Discs are free (steel or iron only – bells are free)
- 5.6.6.2.2 Pads are free.
- 5.6.6.2.3 Calipers must remain standard (AP two pot fronts and Brembo sliding caliper rear).
- 5.6.6.2.4 Master cylinder must remain standard (single dual circuit item).
- 5.6.6.2.5 Brake flexible hoses are free (stainless steel braided recommended).
- 5.6.6.2.6 Fluid must be DOT 4 or 5.1.
- 5.6.6.3 Wheels:** **Production**
- 5.6.6.3.1 Max rim size front 7J16 min ET30 and rear 8J17 min ET35.
- 5.6.6.3.2 All Wheels must be of metal construction with the exception of Magnesium which is not permitted. Multi-piece wheels are not permitted.

**2011 Lotus Cup UK – Sporting & Technical Regulations**

- 5.6.6.4 **Tyres:** **Production**
- 5.6.6.4.1 As supplied control tyre:
- Yokohama A048 LTS or Yokohama AO48R (M compound)
195/50R16
225/45R17
- 5.6.6.4.2 No modifications to the tyres in any way, (any tyres suspected of being treated/modified will be excluded from the meeting).
- 5.6.6.4.3 It is not permitted to fill tyres with nitrogen
- 5.6.6.5 **Weights:** **Production**
- 5.6.6.5.1 Minimum weight of the elise 111r cars including the driver is **945kg**.
- As an example;
- If a driver weighs 75kg the vehicle alone should weigh at least 870kg.
 - If a driver weighs 95kg the vehicle alone should weigh at least 850kg.
- 5.6.6.5.2 Minimum weight of the Exige cars including the driver is **960kg**.
- As an example;
- If a driver weighs 75kg the vehicle alone should weigh at least 885kg.
 - If a driver weighs 95kg the vehicle alone should weigh at least 865kg.
- 5.6.6.5.3 This weight is the minimum the car and driver combined must be in race trim after either a race or qualifying session as defined in J 5.15.1-5 (weight/ballast).
- 5.6.6.5.4 It is forbidden to use ballast to make up the weight (as in no lightening of the car then ballasting them back up).
- 5.6.6.5.5 Ballast may only be applied under direction from the organisers and where required shall be securely fixed in accordance with J 5.15.1-5.
- 5.6.6.5.6 Cars will have additional weight added to their minimum weights depending on vehicle specification. Current penalties are detailed in section 6.1.1.
- 5.6.6.6 **Fuel Tank/Fuel:** **Production**
- 5.6.6.6.1 As per MSA regulation J 5.13.1-13 where appropriate. Only pump fuel as defined by the 2011 MSA Year Book is permitted.
- 5.6.6.6.2 The standard fuel tank (in both dimensions and material) should be used unless replaced with a bag tank as described in MSA regulation K 4.1-3 (safety fuel cells).
- 5.6.6.6.3 All cars must have a minimum of 3L of fuel remaining in the tank at race finish.
- 5.6.6.6.4 Charcoal canister may be removed but a one way or rollover valve, venting to a safe area, must be fitted.

**2011 Lotus Cup UK – Sporting & Technical Regulations****5.7 Group: 2-Eleven****5.7.1 Chassis: 2-Eleven**

- 5.7.1.1 The construction type, design and material must remain as standard. This includes the sub frame.
- 5.7.1.2 No additional bracing/supports can be added, including any stiffening of the rear sub frame. No method of adding stiffness to the chassis and/or subframe is permitted. Only the use of Lotus manufactured and supplied rear track control arm and structural under tray kit (both types) is permitted.
- 5.7.1.3 It is recommended that cars are fitted with full GT4 specification roll cage. Part Number – A127A0058F

5.7.2 Bodywork: 2-Eleven

- 5.7.2.1 All cars must retain the standard road car's profile, and be maintained to a high standard of finish, whilst it's understandable that damage may occur during a weekend, it's important that this is rectified before the next meeting. This is important to keep the image and profile of the series.
- 5.7.2.2 The organisers reserve the right to overrule any part that is felt to be outside the spirit of the series. If in any doubt about what is/is not acceptable, the onus is on the entrant to ask first.
- 5.7.2.3 Vehicles must be fitted with standard Lotus supplied bodywork or OEM bodywork of the same internal and external dimensions and material of the lotus supplied part.
- 5.7.2.4 Interior is free.
- 5.7.2.5 Battery size & type is free and can be moved as long as it is securely mounted and covered.
- 5.7.2.6 A removable steering wheel may be fitted to replace standard component, a spacer may be used.
- 5.7.2.7 The passenger seat, mounts and seatbelts may be removed.
- 5.7.2.8 The windscreen may be removed and replaced with the Lotus rigid tonneau and screen.
- 5.7.2.9 There should be substantial towing eyes securely fixed to the main structure of the vehicle, front and rear, within the confines of the body to enable the vehicle to be moved. Towing eyes should have a minimum internal diameter of 60mm. Towing eyes/towing points should be painted a contrasting bright color (Day-Glo red, orange or yellow).
Q19.1.3
- 5.7.2.10 Carbon fibre front clamshell, body sides, rear bumper are not permitted all other panels are free.
- 5.7.2.11 All body grills may be removed. If removing side intake grills the body work may be fettled to no less than the material thickness of the panel.
- 5.7.2.12 Plastic arch liners may be added for protection to inner wheel arch.
- 5.7.2.13 Lotus Aero Pack comprising adjustable carbon fibre single element rear wing, wing end plates for which material is free but must remain to the original dimensions and extended



2011 Lotus Cup UK – Sporting & Technical Regulations

front splitter is permitted. No modification, including but not limited to the mounting points, the wing or splitter, be it standard or Aero Pack, is permitted.

- 5.7.2.14 All vehicles must be fitted with rear view side mirrors.
- 5.7.2.15 All vehicles must be fitted with Lotus 2-Eleven brake lights and rear fog lights (the latter complying with MSA regulation K5.1).
- 5.7.2.16 Headlamps, front direction indicators and side repeaters including associated mountings are optional. However, if all front lights are removed two driving lamps must be fitted and be in effective working condition.
- 5.7.3 Engine: 2-Eleven**
- 5.7.3.1 No engine modification is permitted including, but not limited to, engine control unit mapping and engine internal components.
- 5.7.3.2 Exhaust silencer is free.
- 5.7.3.3 Exhaust manifolds are restricted to the standard 211 part reference A120E6331S or the GT4 upgrade manifold part number ALS3E0281F.
- 5.7.3.4 Lotus 2-ELEVEN 260PS ECM upgrade is permitted, part number "ALS3M0352F ECM, 260PS UPGRADE, 2-ELEVEN". The Lotus 270 GT4 upgrade (comprising GT4 ECU, GT4 pulley and GT4 exhaust manifold) is permitted but cars must not exceed the stated maximum power in 5.7.3.5
- 5.7.3.5 Vehicle power is limited to **248bhp at the hubs** (allows use of 260 upgrade). Please note this is our measured power and not officially advertised power figures.
- 5.7.3.6 The power limit must be strictly adhered too – the organisers advise all drivers that their cars **MUST** be under this maximum as there will be no excuses should they be found to exceed them.
- 5.7.3.7 The compressor pulley must not be smaller than 76.5mm measured from the outer teeth to outer teeth – see Appendix 6.6 and must not be modified in any way.
- 5.7.3.8 The crank shaft pulley must be the standard Lotus part reference A120E6198S and must not be modified in any way.
- 5.7.3.9 Vehicles may be fitted with an additional oil temperature and pressure gauge.
- 5.7.3.10 Air filter and housing is free.
- 5.7.3.11 Vehicles may be fitted with the Lotus supplied Twin Air/Oil Coolers. Laminova oil coolers for gear box and engine are permitted. A baffled sump is permitted.
- 5.7.3.12 Lotus supplied lightweight fly wheel is permitted.
- 5.7.3.13 Mesh may be added to front and rear of Air/Oil cooler.
- 5.7.3.14 Lotus Dry Sump System (ALS3E0338F) may be fitted however all vehicles running this **MUST** be submitted to TDI (Ref 5.5.3 of these regulations) and be under the specified power limit before they can be permitted to race. This also carries a 15Kg weight penalty.
- 5.7.3.15 Lotus engine mount upgrade is permitted, part numbers:
ALS3E0264F Engine Mount, Front, Bush, Upgrade

**2011 Lotus Cup UK – Sporting & Technical Regulations**

ALS3E0265F Engine Mount, Rear, Bush, Upgrade

5.7.4 Suspensions: 2-Eleven

- 5.7.4.1 Damper make is free but may only be a maximum of two way adjustable.
- 5.7.4.2 Front damper brackets to the chassis may be replaced by the Lotus motorsport adjustable mount to raise or lower the upper damper mounting point.
- 5.7.4.3 Springs are free including the use of helper springs.
- 5.7.4.4 Vehicles may be fitted with polyurethane or nylatron suspension bushes.
- 5.7.4.5 Up rated inner rear toe links may be fitted however mounting points must be the same as standard.

5.7.5 Ride Height and Ground Clearance: 2-Eleven

- 5.7.5.1 See diagram 6.4 in appendices showing illustration of where ride height should be observed on the vehicle.
- 5.7.5.2 No part of the car between all 4 wheel centres (excluding mud flaps) may be below 85mm.
- 5.7.5.3 No part of the car (excluding mud flaps) should be below 65mm.

5.7.6 Transmission: 2-Eleven

- 5.7.6.1 Any modification is prohibited, with the exception of fitment of the Lotus motorsport clutch and third party optional gear sets. Different gear sets &/or final drive ratios to standard will carry a 10kg weight penalty.
- 5.7.6.2 An alternative sequential gearbox with 6 gears may be fitted in replacement to the original gearbox. If a sequential gearbox is fitted cars must produce a valid power test from TDI to show the car does not exceed the specified maximum power. In addition the OBD port and the ECU to the wiring looming will have a seal applied by the organisers and specifications, sizes and photo's taken of other relevant parts including, but not limited to: S/C pulley, manifold, air intake system. If a seal is broken or the specification found to have changed the car must be resubmitted to TDI to produce another valid power test before the car is permitted to race. If the seal is broken at a race weekend the organisers should be notified beforehand and a seal will be re-applied without the need for a retest. A 30kg weight penalty will be applied to all cars with a sequential gearbox.
- 5.7.6.3 LSDs are permitted.

5.7.7 Electrics: 2-Eleven

- 5.7.7.1 Any modification is prohibited with the exception of modifications required for fitment of a battery isolation switch (mechanical or electrical type), Lotus supplied Anderson Plug External Connector and Cables, Accusump oil accumulator and associated wiring, fire extinguisher, FIA fuel drain, sensor for oil pressure/temperature and fuel pressure. Modifications can also be made to aid moving the battery.

5.7.8 Brakes: 2-Eleven

- 5.7.8.1 Disks are free (steel or iron only – bells are free).
- 5.7.8.2 Pads are free.



2011 Lotus Cup UK – Sporting & Technical Regulations

- 5.7.8.3 Fluid must be DOT 4 or 5.1.
- 5.7.8.4 Callipers are free, but no modifications are permitted to the hubs, up rights, steering arms or camber blocks.
Advisory Note: The disabling of the ABS system is strongly advised against when running any of the standard Lotus braking system as this will adversely affect the performance of the braking system and balance of the vehicle under braking.
- 5.7.8.5 The use of Lotus Twin Master Cylinder Braking system ALS3J0174F is permitted and recommended for those wishing to disable the ABS system. This carries a 10Kg weight penalty.
- 5.7.9 **Wheels:** 2-Eleven
- 5.7.9.1 Max rim size front 7J16 min ET30 and rear 8J17 min ET35.
- 5.7.9.2 All Wheels must be of metal construction with the exception of Magnesium which is not permitted. Multi-piece wheels are not permitted.
- 5.7.10 **Tyres:** 2-Eleven
- 5.7.10.1 As supplied control tyre:

Yokohama A048 LTS or Yokohama AO48R (M compound)
195/50R16
225/45R17
- 5.7.10.2 No modifications to the tyres in any way, (any tyres suspected of being treated/modified will be excluded from the meeting).
- 5.7.10.3 It is not permitted to fill tyres with nitrogen
- 5.7.11 **Weights:** 2-Eleven
- 5.7.11.1 Minimum weight of the vehicle including the driver is **815kg**.

As an example;
- If a driver weighs 75kg the vehicle alone should weigh at least 740kg.
 - If a driver weighs 95kg the vehicle alone should weigh at least 720kg.
- 5.7.11.2 This weight is the minimum the car and driver combined must be in race trim after either a race or qualifying session as defined in J 5.15.1-5 (weight/ballast).
- 5.7.11.3 It is forbidden to use ballast to make up the weight (as in no lightening of the car then ballasting them back up).
- 5.7.11.4 Ballast may only be applied under direction from the organisers and where required shall be securely fixed in accordance with J 5.15.1-5.
- 5.7.11.5 Individual cars will have additional weight added to their minimum weights depending on vehicle specification. Current penalties are detailed in section 6.1.2.
- 5.7.12 **Fuel Tank/Fuel:** 2-Eleven
- 5.7.12.1 As per MSA regulation J 5.13.1-13 where appropriate. Only pump fuel as defined by the 2011 MSA Year Book is permitted.

**2011 Lotus Cup UK – Sporting & Technical Regulations**

5.7.12.2 The standard fuel tank (in both dimensions and material) should be used unless replaced with the Lotus 70 litre FIA FT3 bag fuel tank. However, alternative fuel tanks will be considered on request.

5.7.12.3 All cars must have a minimum of 3L of fuel remaining in the tank at race finish.

5.8 Group: Exige Cup**5.8.1 Chassis:****Exige Cup**

5.8.1.1 The construction type, design and material must remain as standard. This includes the sub frame.

5.8.1.2 No additional bracing/supports can be added, including any stiffening of the rear sub frame. No method of adding stiffness to the chassis and/or subframe is permitted. Only the use of Lotus manufactured and supplied rear track control arm and structural under tray kit (both types) is permitted.

5.8.2 Bodywork:**Exige Cup**

5.8.2.1 All cars must retain the standard road car's profile, and be maintained to a high standard of finish, whilst it's understandable that damage may occur during a weekend, it's important that this is rectified before the next meeting. This is important to keep the image and profile of the series.

5.8.2.2 The organisers reserve the right to overrule any part that is felt to be outside the spirit of the series. If in any doubt about what is/is not acceptable, the onus is on the entrant to ask first.

5.8.2.3 Vehicles must be fitted with standard Lotus supplied bodywork or OEM bodywork of the same internal and external dimensions and material of the Lotus supplied part.

5.8.2.4 Permitted body modifications are:

5.8.2.4.1 Front splitters may be fitted within the width of the bodywork, (excluding wing mirrors) and may project a maximum of 30mm beyond the body work measured by a plum line from the front of clam. An additional front spoiler as shown in section 6.5 may also be fitted but must comply with ground clearance rules in 5.8.5. Material is free.

5.8.2.4.2 Under trays must not exceed overall dimensions of the standard part. Ducts and holes within the tray may be relocated and material is free. Rear diffuser section may be extended rearwards.

5.8.2.4.3 Extended rear diffuser protruding no more than 50mm from the rear bodywork and complying with the ground clearance rules in 5.8.5 are permitted. Material is free.

5.8.2.4.4 A single element rear wing may be fitted to the maximum width of 1300mm (Lotus Motorsport) and have a maximum rear dimension not exceeding the original length of the car excluding any diffuser. All parts of the wing, excluding end plates, must be below 1100mm from the floor and have a maximum cord length of 300mm. End plates are allowed (one each end) but must be no larger than 320x200mm with rounded corners. Material is free. The wing can be fitted to the rear clam or the rear tailgate.

5.8.2.4.5 Side scoops may be fitted, but must not protrude further than the side profile of the car. Material is free.

**2011 Lotus Cup UK – Sporting & Technical Regulations**

- 5.8.2.4.6 Side scoop inner vents may be removed but the external holes in the clam must be standard size and profile
- 5.8.2.4.7 Roof scoops may be fitted as per Lotus Cup 260 specification. Material is free.
- 5.8.2.4.8 The clam under rear grills (reverse lights) may be removed however the grill must remain.
- 5.8.2.4.9 The body behind the number plate can be removed to an area no larger than a standard number plate (520mm x 130mm). If a hole is created it should be covered in mesh.
- 5.8.2.4.10 Wheel arch liners may be removed and the inner lip of the wheel arch reduced to allow tyre clearance.
- 5.8.2.4.11 The boot/engine bay divider may be removed or modified
- 5.8.2.4.12 Rear Bulkhead may be removed and replaced with a solid metallic sheet (ala.Lotus Motorsport). It is essential that this is carried out in such a way that the passenger cabin is sealed from the engine compartment.
- 5.8.2.4.13 The front 'ducts' on an Exige/Motor Sport clam can be opened up for cooling ducts but only to the extent of the std moulding (i.e. they cannot be made larger)
- 5.8.2.5 Interior may be removed and replaced as required within MSA requirements. Material is free. Sequential gear lever mechanism, not to be confused with a full sequential gearbox, can be fitted.
- 5.8.2.6 A removable steering wheel may be fitted. Material is free.
- 5.8.2.7 The passenger seat, mounts and seatbelts may be removed.
- 5.8.2.8 Side windows may be replaced with Perspex alternatives, this can include a slider. Electric window motors may be removed.
- 5.8.2.9 Rear tailgate can be replaced with lightweight version. This part can be removable so gas strut and hinges can be removed. Material is free.
- 5.8.2.10 Headlamps, front direction indicators and side repeaters including associated mountings are optional. However, if all front lights are removed two driving lamps must be fitted and be in effective working condition.
- 5.8.2.11 There should be substantial towing eyes securely fixed to the main structure of the vehicle, front and rear, within the confines of the body to enable the vehicle to be moved. Towing eyes should have a minimum internal diameter of 60mm. Towing eyes/towing points should be painted a contrasting bright color (Day-Glo red, orange or yellow). (G99)
- 5.8.2.12 Carbon fibre body panels are permitted where Lotus currently provide a factory option.
- 5.8.3 Engine: Exige Cup**
- 5.8.3.1 Engine must remain original i.e. Toyota 2ZZ-GE (189bhp flywheel) or 2ZZ-GZE (equipped with an Eaton MP62 supercharger and intercooler). Alternative super charger and intercooler systems will be considered on an individual basis.
- 5.8.3.2 No engine modifications are permitted including, but not limited to engine internal components. With the exception of the exhaust system and engine ECU, air filter, cams and mapping which are all free.



2011 Lotus Cup UK – Sporting & Technical Regulations

- 5.8.3.3 Power must not exceed a maximum power output of 260BHP at the hubs as measured by TDI.
- 5.8.3.4 The power limit must be strictly adhered too – the organisers advise all drivers that their cars MUST be under this maximum as there will be no excuses should they be found to exceed them.
- 5.8.3.5 Vehicles may be fitted with an additional oil temperature and pressure gauge.
- 5.8.3.6 Air filter and housing is free.
- 5.8.3.7 Vehicles may be fitted with the Lotus supplied Twin Air/Oil Coolers. Laminova oil coolers for gear box and engine are permitted. A baffled sump is permitted.
- 5.8.3.8 Lotus Dry Sump System (ALS3E0338F) may be fitted however all vehicles running this MUST be submitted to TDI and be under the specified power limit before they can be permitted to race. This also carries a 15Kg weight penalty.

5.8.4 Suspensions: **Exige Cup**

- 5.8.4.1 Damper make is free but may only be a maximum of two way adjustable.
- 5.8.4.2 Front damper brackets to the chassis may be replaced by the Lotus motorsport adjustable mount to raise or lower the upper damper mounting point.
- 5.8.4.3 Springs are free including the use of helper springs.
- 5.8.4.4 Vehicles may be fitted with polyurethane or nylatron suspension bushes.
- 5.8.4.5 Up rated inner rear toe links may be fitted however mounting points must be the same as standard. Front upper wishbones and steering arms can be as factory supplied to Lotus Exige or Lotus 211.

5.8.5 Ride Height and Ground Clearance: **Exige Cup**

- 5.8.5.1 See diagram 6.4 in appendices showing illustration of where ride height should be observed on the vehicle.
- 5.8.5.2 No part of the car between all 4 wheel centres (excluding mud flaps) may be below 95mm.
- 5.8.5.3 No part of the car (excluding mud flaps) should be below 65mm.

5.8.6 Transmission: **Exige Cup**

- 5.8.6.1 Any modification is prohibited, with the exception of fitment of the Lotus motorsport clutch and third party optional gear sets. Different gear sets &/or final drive ratios to standard will carry a 10kg weight penalty.
- 5.8.6.2 An alternative sequential gearbox with 6 gears may be fitted in replacement to the original gearbox. If a sequential gearbox is fitted cars must produce a valid power test from TDI to show the car does not exceed the specified maximum power. In addition the OBD port and the ECU to the wiring looming will have a seal applied by the organisers and specifications, sizes and photo's taken of other relevant parts including, but not limited to: S/C pulley, manifold, air intake system. If a seal is broken or the specification found to have changed the car must be resubmitted to TDI to produce another valid power test before the car is permitted to race. If the seal is broken at a race weekend the



2011 Lotus Cup UK – Sporting & Technical Regulations

organisers should be notified beforehand and a seal will be re-applied without the need for a retest. A 30kg weight penalty will be applied to all cars with a sequential gearbox.

5.8.6.3 LSDs are permitted.

5.8.6.4 Lotus engine mount upgrade is permitted, part numbers:

ALS3E0264F Engine Mount, Front, Bush, Upgrade

ALS3E0265F Engine Mount, Rear, Bush, Upgrade

5.8.7 Electrics: **Exige Cup**

5.8.7.1 Any modification is prohibited with the exception of modifications required for fitment of a battery isolation switch (mechanical or electrical type), Lotus supplied Anderson Plug External Connector and Cables, Accusump oil accumulator and associated wiring, fire extinguisher, FIA fuel drain, sensor for oil pressure/temperature and fuel pressure. The battery size & type is free and it may be relocated provided at a safe location.

5.8.8 Brakes: **Exige Cup**

5.8.8.1 Disks are free (steel or iron only – bells are free).

5.8.8.2 Pads are free.

5.8.8.3 Fluid must be DOT 4 or 5.1.

5.8.8.4 Callipers are free, but no modifications are permitted to the hubs, up rights, steering arms or camber blocks. *Advisory Note: The disabling of the ABS system is strongly advised against when running any of the standard Lotus braking system as this will adversely affect the performance of the braking system and balance of the vehicle under braking.*

5.8.8.5 The use of Lotus Twin Master Cylinder Braking system ALS3J0174F is permitted and recommended for those wishing to disable the ABS system. This carries a 10Kg weight penalty.

5.8.9 Wheels: **Exige Cup**

5.8.9.1 Max rim size front 7J16 min ET30 and rear 8J17 min ET35.

5.8.9.2 All Wheels must be of metal construction with the exception of Magnesium which is not permitted. Multi-piece wheels are not permitted.

5.8.10 Tyres: **Exige Cup**

5.8.10.1 As supplied control tyre:

Yokohama A048 LTS or Yokohama AO48R (M compound)
195/50R16
225/45R17

5.8.10.2 No modifications to the tyres in any way, (any tyres suspected of being treated/modified will be excluded from the meeting).

5.8.10.3 It is not permitted to fill tyres with nitrogen

5.8.11 Weights: **Exige Cup**

5.8.11.1 Minimum weight of the vehicle including the driver is **910kg**.



2011 Lotus Cup UK – Sporting & Technical Regulations

As an example;

- If a driver weighs 75kg the vehicle alone should weigh at least 835kg.
- If a driver weighs 95kg the vehicle alone should weigh at least 815kg.

- 5.8.11.2 This weight is the minimum the car and driver combined must be in race trim after either a race or qualifying session as defined in J 5.15.1-5 (weight/ballast).
- 5.8.11.3 It is forbidden to use ballast to make up the weight (as in no lightening of the car then ballasting them back up).
- 5.8.11.4 Ballast may only be applied under direction from the organisers and where required shall be securely fixed in accordance with J 5.15.1-5.
- 5.8.11.5 Individual cars will have additional weight added to their minimum weights depending on vehicle specification. Current penalties are detailed in section 6.1.2.

5.8.12 **Fuel Tank/Fuel:** **Exige Cup**

- 5.8.12.1 As per MSA regulation J 5.13.1-13 where appropriate. Only pump fuel as defined by the 2011 MSA Year Book is permitted.
- 5.8.12.2 The standard fuel tank (in both dimensions and material) should be used unless replaced with the Lotus 70 litre FIA FT3 bag fuel tank. However, alternative fuel tanks will be considered on request.
- 5.8.12.3 All cars must have a minimum of 3L of fuel remaining in the tank at race finish.

5.9 **Group: Lotus Open**

5.9.1 **Chassis:** **Lotus Open**

- 5.9.1.1 The construction type, design and material must remain as standard. This includes the sub frame.
- 5.9.1.2 No additional bracing/supports can be added, including any stiffening of the rear sub frame. No method of adding stiffness to the chassis and/or subframe is permitted. Only the use of Lotus manufactured and supplied rear track control arm and structural under tray kit (both types) is permitted.

5.9.2 **Bodywork:** **Lotus Open**

- 5.9.2.1 All cars must retain the standard road car's profile, and be maintained to a high standard of finish, whilst it's understandable that damage may occur during a weekend, it's important that this is rectified before the next meeting. This is important to keep the image and profile of the series.
- 5.9.2.2 The organisers reserve the right to overrule any part that is felt to be outside the spirit of the series. If in any doubt about what is/is not acceptable, the onus is on the entrant to ask first.
- 5.9.2.3 Vehicles must be fitted with standard Lotus supplied bodywork or OEM bodywork of the same internal and external dimensions and material of the Lotus supplied part.
- 5.9.2.4 Permitted body modifications are: Each vehicle is accepted on an invitation basis. Vehicles will be considered upon individual requests.

**2011 Lotus Cup UK – Sporting & Technical Regulations****5.9.3 Engine: Lotus Open**

- 5.9.3.1 The original Engine must be maintained.
- 5.9.3.2 Power must not exceed a maximum power output of 240BHP at the hubs as measured by TDI. All Lotus Open cars must go to TDI before competing in the series unless given an exception from the organisers for exceptional circumstances.
- 5.9.3.3 Toyota engines must remain original i.e. Toyota 2ZZ-GE (189bhp flywheel) or 2ZZ-GZE (equipped with an Eaton MP62 supercharger and intercooler). Alternative super charger and intercooler systems will be considered on an individual basis for Toyota engined cars. Europa turbos must be standard.
- 5.9.3.4 Toyota engined cars are not permitted any engine modifications including, but not limited to engine internal components. With the exception of the exhaust system and engine ECU, air filter, baffled sump, cams and mapping which are all free.
- 5.9.3.5 Cars with non-original engines &/or turbos may be accepted into the Lotus Open group by invite on a round by round basis. They will not be permitted to compete at rounds 4, 5, 7 & 8 but drivers will be permitted to compete in an alternative car and points accumulated.

5.9.4 Suspensions: Lotus Open

- 5.9.4.1 Damper make is free but may only be a maximum of two way adjustable.
- 5.9.4.2 Front damper brackets to the chassis may be replaced by the Lotus motorsport adjustable mount to raise or lower the upper damper mounting point.
- 5.9.4.3 Springs are free including the use of helper springs.
- 5.9.4.4 Vehicles may be fitted with polyurethane or nylatron suspension bushes.
- 5.9.4.5 Up rated inner rear toe links may be fitted however mounting points must be the same as standard. Front upper wishbones and steering arms can be as factory supplied to Lotus Exige or Lotus 211.

5.9.5 Ride Height and Ground Clearance: Lotus Open

- 5.9.5.1 See diagram 6.4 in appendices showing illustration of where ride height should be observed on the vehicle.
- 5.9.5.2 No part of the car between all 4 wheel centres (excluding mud flaps) may be below 95mm.
- 5.9.5.3 No part of the car (excluding mud flaps) should be below 65mm.

5.9.6 Transmission: Lotus Open

- 5.9.6.1 Any modification is prohibited, with the exception of fitment of the Lotus motorsport clutch and third party optional gear sets. Different gear sets &/or final drive ratios to standard will carry a 10kg weight penalty.
- 5.9.6.2 An alternative sequential gearbox with 6 gears may be fitted in replacement to the original gearbox. If a sequential gearbox is fitted cars must produce a valid power test from TDI to show the car does not exceed the specified maximum power. In addition the OBD port and the ECU to the wiring looming will have a seal applied by the organisers and specifications, sizes and photo's taken of other relevant parts including, but not

**2011 Lotus Cup UK – Sporting & Technical Regulations**

limited to: S/C pulley, manifold, air intake system. If a seal is broken or the specification found to have changed the car must be resubmitted to TDI to produce another valid power test before the car is permitted to race. If the seal is broken at a race weekend the organisers should be notified beforehand and a seal will be re-applied without the need for a retest. A 30kg weight penalty will be applied to all cars with a sequential gearbox.

5.9.6.3 LSDs are permitted.

5.9.6.4 Lotus engine mount upgrade is permitted, part numbers:

ALS3E0264F Engine Mount, Front, Bush, Upgrade
ALS3E0265F Engine Mount, Rear, Bush, Upgrade

5.9.7 Electrics: Lotus Open

5.9.7.1 Any modification is prohibited with the exception of modifications required for fitment of a battery isolation switch (mechanical or electrical type), Lotus supplied Anderson Plug External Connector and Cables, Accusump oil accumulator and associated wiring, fire extinguisher, FIA fuel drain, sensor for oil pressure/temperature and fuel pressure. The battery size & type is free and it may be relocated provided at a safe location.

5.9.8 Brakes: Lotus Open

5.9.8.1 Disks are free (steel or iron only – bells are free).

5.9.8.2 Pads are free.

5.9.8.3 Fluid must be DOT 4 or 5.1.

5.9.8.4 Callipers are free, but no modifications are permitted to the hubs, up rights, steering arms or camber blocks. *Advisory Note: The disabling of the ABS system is strongly advised against when running any of the standard Lotus braking system as this will adversely affect the performance of the braking system and balance of the vehicle under braking.*

5.9.8.5 The use of Lotus Twin Master Cylinder Braking system ALS3J0174F is permitted and recommended for those wishing to disable the ABS system. This carries a 10Kg weight penalty.

5.9.9 Wheels: Lotus Open

5.9.9.1 Max rim size front 7J16 min ET30 and rear 8J17 min ET35.

5.9.9.2 All Wheels must be of metal construction with the exception of Magnesium which is not permitted. Multi-piece wheels are not permitted.

5.9.10 Tyres: Lotus Open

5.9.10.1 As supplied control tyre:

Yokohama A048 LTS or Yokohama AO48R (M compound)

5.9.10.2 No modifications to the tyres in any way, (any tyres suspected of being treated/modified will be excluded from the meeting).

5.9.10.3 It is not permitted to fill tyres with nitrogen

5.9.11 Weights: Lotus Open

**2011 Lotus Cup UK – Sporting & Technical Regulations**

- 5.9.11.1 The Lotus Open Group is based on power to weight with a maximum of 285.7 bhp per tonne. Thus for example:-
- A Vehicle with 240bhp must weigh no less than 840Kg
 - A Vehicle with 230bhp must weigh no less than 805Kg
 - A vehicle with 220bhp must weigh no less than 770Kg
- 5.9.11.2 This weight is the minimum the car and driver combined must be in race trim after either a race or qualifying session.
- 5.9.11.3 It is forbidden to use ballast to make up the weight (as in no lightening of the car then ballasting them back up).
- 5.9.11.4 Ballast may only be applied under direction from the organisers and where required shall be securely fixed in accordance with J.5.15.1-5.
- 5.9.11.5 Individual cars will have additional weight added to their minimum weights depending on vehicle specification. Current penalties are detailed in section 6.1.2.

5.9.12 Fuel Tank/Fuel: Lotus Open

- 5.9.12.1 As per MSA regulation J 5.13.1-13 where appropriate. Only pump fuel as defined by the 2011 MSA Year Book is permitted.
- 5.9.12.2 The standard fuel tank (in both dimensions and material) should be used unless replaced with the Lotus 70 litre FIA FT3 bag fuel tank. However, alternative fuel tanks will be considered on request.
- 5.9.12.3 All cars must have a minimum of 3L of fuel remaining in the tank at race finish.

5.10 Group: Evora**5.10.1 Chassis: Evora**

- 5.10.1.1 The construction type, design and material must remain as standard production or Lotus Motorsport specification. This includes the sub frame.
- 5.10.1.2 No additional bracing/supports can be added, including any stiffening of the rear sub frame. No method of adding stiffness to the chassis and/or subframe is permitted.

5.10.2 Bodywork: Evora

- 5.10.2.1 All cars must retain the standard road car's profile or Evora Cup/GT4 specification, and be maintained to a high standard of finish, whilst it's understandable that damage may occur during a weekend, it's important that this is rectified before the next meeting. This is important to keep the image and profile of the series.
- 5.10.2.2 The organisers reserve the right to overrule any part that is felt to be outside the spirit of the series. If in any doubt about what is/is not acceptable, the onus is on the entrant to ask first.
- 5.10.2.3 Vehicles must be fitted with standard Lotus supplied bodywork or OEM bodywork of the same internal and external dimensions and material of the lotus supplied part.

5.10.3 Engine: Evora

- 5.10.3.1 The original Engine must be maintained as supplied from the factory including Evora NA, Evora S and Cosworth GT4.



2011 Lotus Cup UK – Sporting & Technical Regulations

5.10.3.2 Power must not exceed a maximum power output of 360BHP at the hubs as measured by TDI. All Evora cars must go to TDI before competing in the series unless given an exception from the organisers for exceptional circumstances.

5.10.4 Ride Height and Ground Clearance: **Evora**

5.10.4.1 See diagram 6.4 in appendices showing illustration of where ride height should be observed on the vehicle.

5.10.4.2 No part of the car between all 4 wheel centres (excluding mud flaps) may be below 95mm.

5.10.4.3 No part of the car (excluding mud flaps) should be below 65mm.

5.10.5 Tyres: **Evora**

5.10.5.1 As supplied control tyre:

Yokohama A048 LTS or Yokohama AO48R (M or MH compound)

5.10.5.2 No modifications to the tyres in any way, (any tyres suspected of being treated/modified will be excluded from the meeting).

5.10.5.3 It is not permitted to fill tyres with nitrogen

5.10.6 Weights: **Evora**

5.10.6.1 Minimum weight of the vehicle including the driver is **1260kg**.

As an example;

- If a driver weighs 75kg the vehicle alone should weigh at least 1185kg.
- If a driver weighs 95kg the vehicle alone should weigh at least 1165kg.

5.10.6.2 This weight is the minimum the car and driver combined must be in race trim after either a race or qualifying session as defined in J 5.15.1-5 (weight/ballast).

5.10.6.3 It is forbidden to use ballast to make up the weight (as in no lightening of the car then ballasting them back up).

5.10.6.4 Ballast may only be applied under direction from the organisers and where required shall be securely fixed in accordance with J 5.15.1-5.

5.10.6.5 Individual cars will have additional weight added to their minimum weights depending on vehicle specification. Current penalties are detailed in section 6.1.2.

5.10.7 Fuel Tank/Fuel: **Evora**

5.10.7.1 As per MSA regulation J 5.13.1-13 where appropriate. Only pump fuel as defined by the 2011 MSA Year Book is permitted.

5.10.7.2 The standard fuel tank (in both dimensions and material) should be used unless replaced with the Lotus 96 litre FIA FT3 bag fuel tank.

5.10.7.3 All cars must have a minimum of 3L of fuel remaining in the tank at race finish.



2011 Lotus Cup UK – Sporting & Technical Regulations

NOTE for ALL Groups: If your car differs in a small way to these regulations please inform us as we may be able to accept it if the car is within the spirit of the regs and no advantage is gained.

5.11 Numbers/Decals for all Groups

5.11.1 MSA Regulations Q 11.1-3 apply regarding competition numbers and backgrounds which must be displayed to the satisfaction of the Timekeepers.

5.11.2 Series livery will be provided by the organisers for display on all cars for;

- Sill panel series sponsor logos (both sides)
- Door cards (both sides) with one set of numbers
- LoTRDC decals (both sides)
- MSVR decals (both sides)
- Windscreen sun visor
- Front number panel
- Rear number plate

Other series decals as from time to time may be required.

5.11.3 Series livery will be positioned as numbered and defined in 6.3.

5.11.4 Drivers will be required to display two series sponsor logos on race suits.

5.11.5 Drivers may be required to display an MSVR badge on their overalls.

5.11.6 The organisers will supply one set of series livery. Replacement vinyl can be purchased from the LoTRDC shop.

5.11.7 Competitors will not be allowed to display sponsor logos (e.g. tyre manufacturers) which conflict with Championship sponsor logos. The only exception to this is where the driver/entrant is the owner/director of the company in question.

5.11.8 Trade Support Vehicle Decals

5.11.8.1 Championship decals will be provided and may be fixed to championship trade support vehicles if wished.

5.11.8.2 Trade support vehicles should not display sponsor logos which conflict with Championship sponsor logos when in the Lotus Cup UK Paddock.

Advertising and sponsorship on all race cars, trucks or overalls of any competitor entering the Lotus Cup UK championship must conform to the MSA Bluebook definitions of legality and decency. Competitors will be asked to remove any signage that might be deemed offensive or inappropriate. Competitors are encouraged to seek the permission of the championship organizers in cases where there is uncertainty.

2011 Lotus Cup UK – Sporting & Technical Regulations

6 APPENDICES

6.1 Weight Penalties

6.1.1 Group: Production

6.1.1.1	S2 Toyota Engine Elise 111r	Minimum Weight = 945kg*
6.1.1.2	S2 Toyota Engine Elise Exige	Minimum Weight = 960kg*

* This weight includes the standard 85kg driver allowance

6.1.2 Groups: 2-Eleven, Exige Cup, Lotus Open & Evora

6.1.2.1	Sequential Gearbox	Minimum Weight + 30kg
6.1.2.2	Close Ratio Gearbox	Minimum Weight + 10kg
6.1.2.3	Twin Master Cylinder Brake System	Minimum Weight + 10kg
6.1.2.4	Lotus Dry Sump System	Minimum Weight + 15kg

6.2 Series Livery Placement

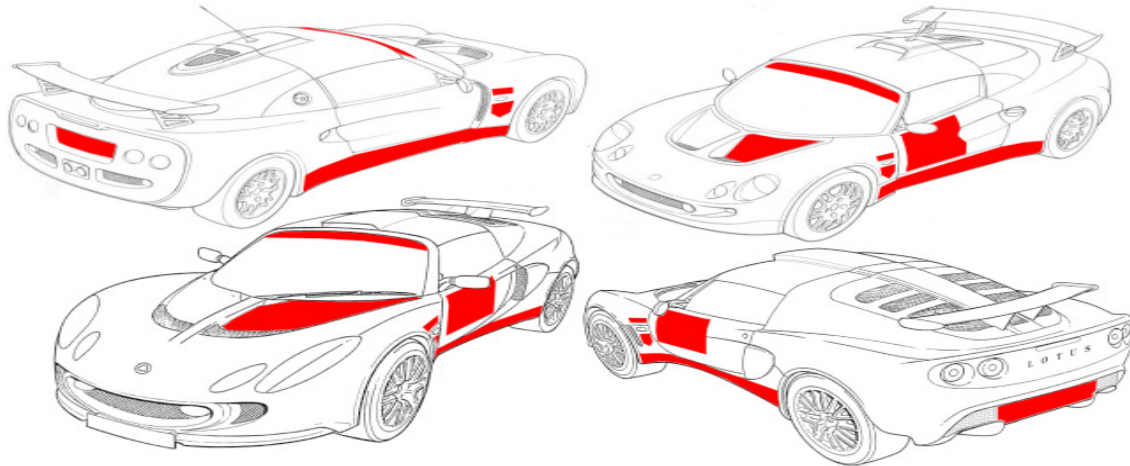

6.3 Ride height measurement area

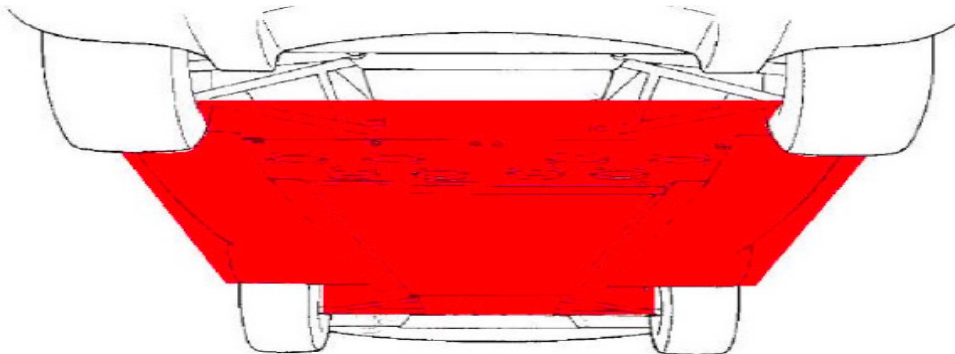

6.4 Permitted Front Spoilers Examples

2011 Lotus Cup UK – Sporting & Technical Regulations



6.5 Two Eleven Compressor pulley measurement

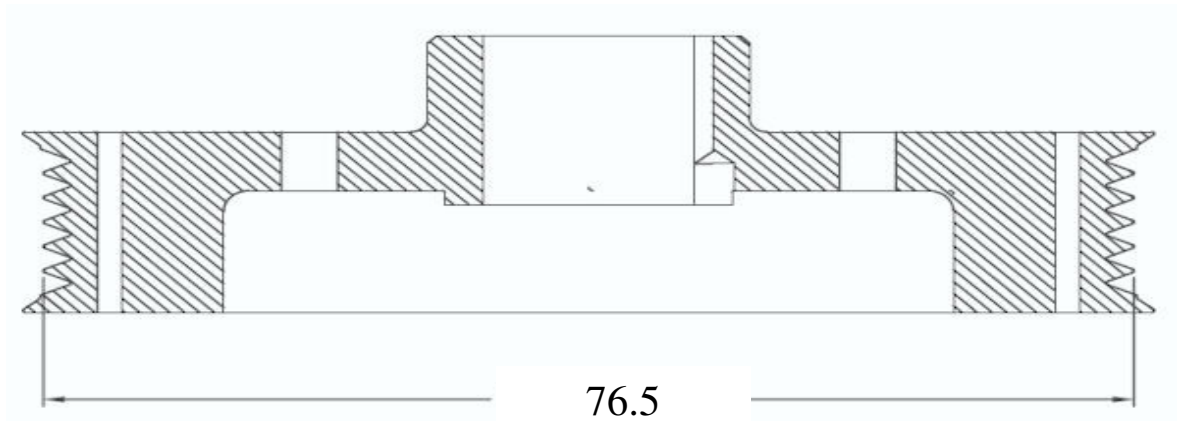

6.6 Intellectual, Commercial, Merchandising and Sponsorship Rights

The Intellectual, Commercial, Merchandising and Sponsorship Rights of the Lotus Cup UK championship are the property of LoTRDC Ltd and may not be assigned to any other party or person without their written agreement. While the permit holder is MotorSport Vision Racing, the sporting ethos for the Lotus Cup UK shall be the domain of LoTRDC Ltd and any changes made to the sporting regulations shall be with the full agreement of LoTRDC Ltd within the framework of the regulations set out by the Motor Sport Association.

6.7 Race Entries

The organisers will be responsible for communicating Race Entry Forms to all Registered Competitors in sufficient time for entries to be made in accordance with Regulation 3.1.2. A single Race Entry Form will be issued which can be used for all races. Once the single Race Entry Form is submitted to the organisers it is the Competitors responsibility to request a new form or download it from the championship website in sufficient time before the race if they wish to enter a race not included on their original single Race Entry Form or obtain such from the official website.

Refunds – if a race entry is withdrawn refunds will be available on receipt of written confirmation of withdrawal received by the Championship Coordinator according to the following schedule:

- i. notification received more than four weeks prior to race meeting 100% refund less £75 administration charge



2011 Lotus Cup UK – Sporting & Technical Regulations

- ii. notification received more than three weeks prior to race meeting 50% refund
- iii. notification received more than two weeks prior to race meeting 25% refund
- iv. less than two weeks notice no refund is available.

Any deposits paid for discounted early race entry prior to 1 February 2011 are non refundable. Entry prices can be obtained separately to these Regulations from the organisers has sole discretion over entry prices and refund policy which they reserve the right to vary from those shown in these Regulations.

Please note Discounts will be available for early entries made prior to 1 January 2011 and for full season entries in the Championship.

Supplementary Regulations, Race meeting Schedules and Paddock details will automatically be issued by email by the organisers to competitors entered in the race.

Each Full Season Entrant will be issued four permanent Circuit Admission Passes. Where required each entrant will also receive Vehicle Passes as appropriate and at the discretion of the Organiser of the race meeting.

Those entering on a race by race basis, or with an accepted late entry, may be issued with four paper circuit admission tickets in place of permanent passes. All Permanent passes will remain the property of MSVR and must be surrendered if required to do so by the Race Meeting organisers. Lost permanent passes will be supplied on written application to MSVR at a charge of £30 per pass. Competitors are responsible for sending in correct and complete entries with the correct entry fees prior to the entry in accordance with Regulation 1.4.1. The championship organisers reserve the right to accept registrations and entries up to noon of the Thursday prior to the race, but an administrative fee may be charged for entries received later than 14 days prior to the event. No entry for the event will be accepted after noon of the Thursday prior to the event.

6.8 Definitions

For the purposes of these regulations a **DRIVER** is *'The person nominated as the driver of a vehicle in any event'*. An **ENTRANT** is *'The person or body responsible for making an Entry into a competition and responsible for all matters pertaining to that entry'*. Both these definitions are given in the MSA yearbook.

It should be noted that licences issued by the MSA to an individual driver afford the driver the rights & privileges of an entrant. MSA regulation **H 27.1.1** states *'All personal licences entitle the holder to enter the car, truck or kart in which he/she will personally take part in the event. Any other organisation, company, sponsor or person must obtain an ENTRANT'S LICENCE by making separate application by completing an Application for Competition Licence Form'*.

A **Competitor** is *'A person or body whose entry is accepted or who competes in any event whatsoever whether as an Entrant, Driver...'* MSA Yearbook.

6.9 Commercial Undertakings:

- i. Entry into the Lotus Cup UK is conditional upon a competitor accepting without reservation or recourse the surrender of his/her rights (if any) for TV filming and broadcast of footage collated during the Championship which may be used at the organisers discretion.
- ii. Competitors are advised that, unless requested otherwise, their information will be stored in a computer retrieval system and may be used for relevant publicity and administration purposes.
- ii. The Championship title and associated logo styles (Lotus Cup UK & LoTRDC Ltd) may only be used with the prior written approval of the Commercial Rights Holder.

6.10 Promotional activities.



2011 Lotus Cup UK – Sporting & Technical Regulations

All competitors taking part in the 2011 Lotus Cup UK events are expected to support the championship in the following ways:

- i. winners in each championship Group must attend the podium as quickly as possible after each event. They must be wearing race overalls, properly fastened and displaying championship badges as requested. If requested to wear a sponsors cap, these will be provided and must be worn as directed.
- ii. All competitors taking part in an event are requested to attend the end of event prize giving in the LoTRDC Ltd race centre 30 mins after the last Lotus Cup UK race of the event to receive trophies and support fellow competitors.
- iii. All competitors are requested to make every effort to attend the official pre-season test day and launch in order to facilitate technical checks on vehicles entering the championship. Information on the test will be sent out to all competitors in good time.

6.11 Television

- 6.11.1 The championship promoter, LoTRDC Ltd, retain exclusive broadcasting, recording, cable, satellite, digital, video, games, internet and interactive rights and rights to all other mediums to film and record the participation of the driver, entrant, sponsor and any other team member in the events and activities throughout the championship and to assign or otherwise deal with such surrender of his/her rights (if any) in such matters, which may then be used at the Championship promoter's discretion.
- 6.11.2 No on-board cameras will be permitted except by permission of the championship organisers. Competitors fitting on-board cameras may also require permission of the circuit management to film and should be prepared to pay any fee required by the circuit if it is deemed that the filming is of a commercial nature. In the event that permission is given for a competitor to fit an on-board camera in his/her race car, the positioning and fitting of the equipment must be approved by the Eligibility Scrutineer prior to that car going on track. It will be mandatory to carry on-board cameras provided by the championship production company or LoTRDC Ltd if required.
- 6.11.3 No sponsorship decals may be carried on the dashboard or in any position that may be visible from an in-car camera without the express permission of the championship organisers.

6.12 Paddock Arrangements

The championship organisers will make every effort to secure suitable paddock space for the Lotus Cup UK competitors at each event. Competitors will be allocated an equal amount of space, those with trucks or motor homes will not be allocated additional space over those who trailer to circuits. Competitors may be required to leave trailers, trucks, road cars or motor homes outside the paddock.